

## **LaserGasPatroller**



## *LaserGasPatroller*



# LGP 800

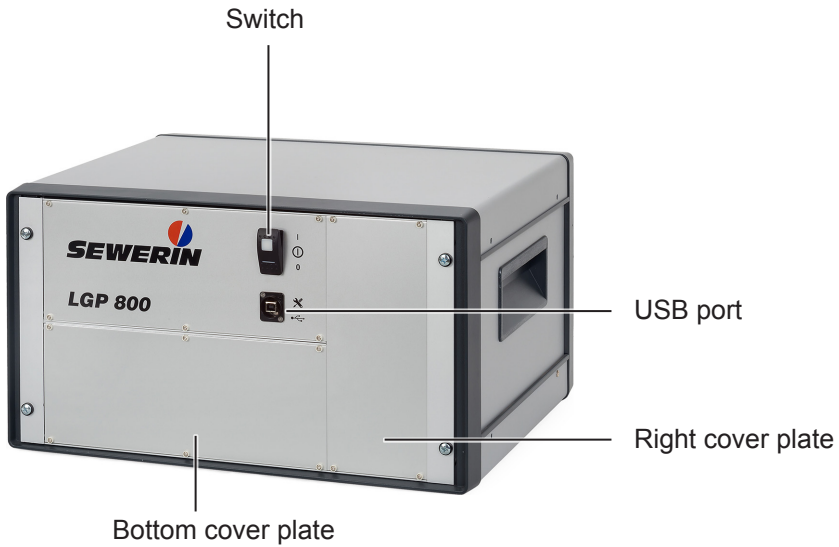

Fig. 1: Front (LGP 800 installed in table housing)

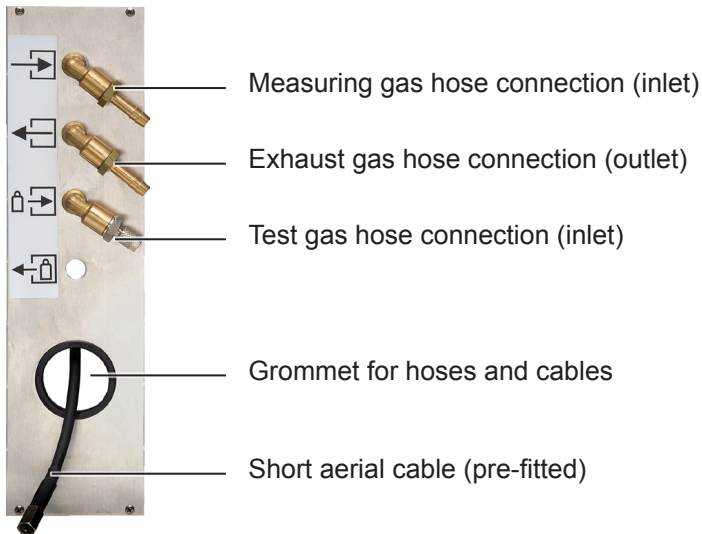

Fig. 2: Gas connections on the back

# LGP 800

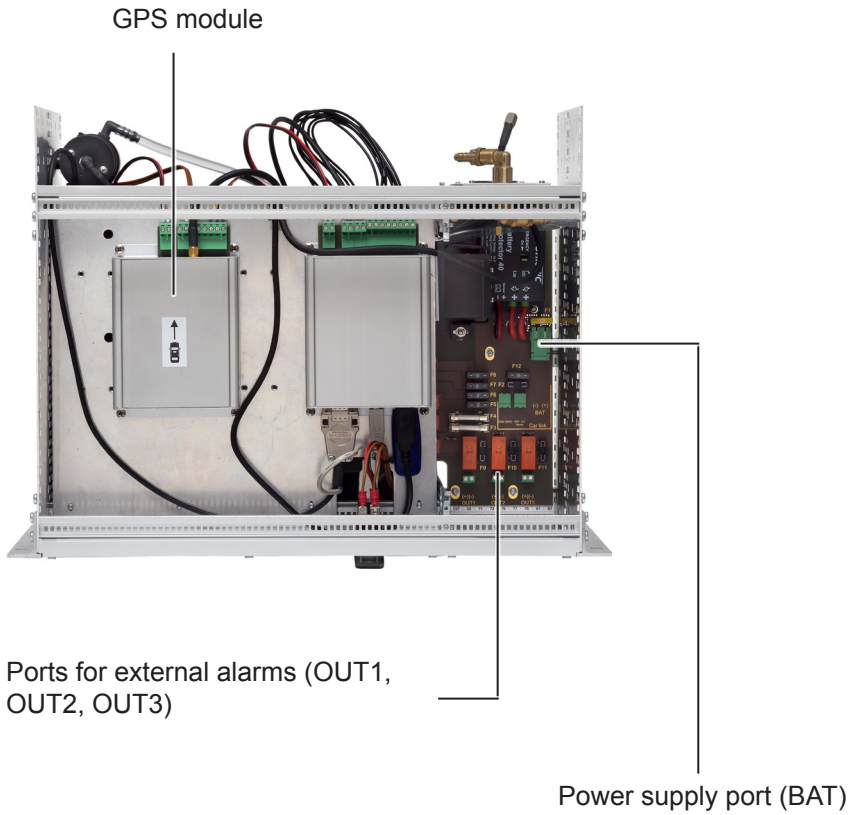

Fig. 3: Top view (cover removed)

## Information about this document

The warnings and notes in the document mean the following:



### **WARNING!**

Risk of personal injury. Can result in serious injury or death.

---



### **CAUTION!**

Risk of personal injury. Can result in injury or a risk to health.

---

---

### **NOTICE!**

Risk of damage to property.

---

---

### **Note:**

Tips and important information.

---

Enumerated lists (numbers, letters) are used for:

- Instructions that must be followed in a specific sequence

Bullet lists (bullet points, dashes) are used for:

- Lists
- Instructions comprising only one action

Windows® is a registered trademark of the Microsoft Corporation. Bluetooth® is a registered trademark of Bluetooth SIG. Viton® is a registered trademark of DuPont Performance Elastomers.

Registered trademarks in this document are not indicated by ®.

---

<b>1</b>	<b>Introduction .....</b>	<b>1</b>
1.1	Warranty .....	1
1.2	Purpose .....	2
1.3	Intended use .....	2
1.4	General safety information .....	3
<b>2</b>	<b>Product description .....</b>	<b>4</b>
2.1	LaserGasPatroller system .....	4
2.2	LGP 800 .....	5
2.3	Optional system upgrade .....	7
<b>3</b>	<b>Assembly, installation and starting up .....</b>	<b>8</b>
3.1	Overview .....	8
3.1.1	General information .....	8
3.1.2	Components .....	9
3.1.3	Hoses .....	10
3.1.4	Cables .....	10
3.2	Procedure in detail .....	12
3.2.1	Assembly work to the vehicle body .....	12
3.2.1.1	Important information .....	12
3.2.1.2	Fitting the suction tree .....	13
3.2.1.3	Fitting the GPS aerial .....	14
3.2.1.4	Fitting the outlet for the exhaust gas hose .....	15
3.2.1.5	Fitting the inlet for the measuring gas hose .....	16
3.2.2	Laying the hoses and cables .....	17
3.2.3	Fitting the LGP 800 – part 1: Preparatory work .....	18
3.2.3.1	Fitting the table housing .....	18
3.2.3.2	Aligning the GPS module in the LGP 800 .....	19
3.2.4	Fitting the SPE LGP .....	20
3.2.5	Connecting the hoses .....	20
3.2.6	Electrical installation .....	22
3.2.6.1	Connecting cables for the power supply .....	22
3.2.6.2	Connecting the cable for the reversing and speed signal .....	24
3.2.6.3	Connecting the aerial cable .....	25
3.2.7	Setting up the system .....	25
3.2.7.1	Pairing the LGP 800 and computer by Bluetooth .....	27
3.2.7.2	Configuring the SeCuRi SAT software .....	28
3.2.7.3	Starting up the system for the first time .....	29
3.2.8	Fitting the LGP 800 – part 2: Installation .....	30

---

---

<b>4</b>	<b>Information on operation and servicing .....</b>	<b>31</b>
4.1	Operation .....	31
4.1.1	Device inspection when starting the system .....	31
4.1.2	Determining the geographical position .....	31
4.1.3	Switching off the system .....	32
4.2	Maintenance.....	32
<b>5</b>	<b>Appendix .....</b>	<b>34</b>
5.1	Technical information: LGP 800 .....	34
5.2	Fuses .....	36
5.3	Accessories and consumables.....	37
5.4	Declaration of conformity .....	38
5.5	Advice on disposal .....	38
<b>6</b>	<b>Index.....</b>	<b>39</b>

# 1 Introduction

## 1.1 Warranty

The following instructions must be complied with in order for any warranty to be applicable regarding functionality and safe operation of this equipment.

- Read these instructions before assembling and installing the product.
- Use the product only as intended.
- Repairs and maintenance must only be carried out by specialist technicians or other suitably trained personnel. Only spare parts approved by Hermann Sewerin GmbH may be used when performing repairs.
- Changes or modifications to this product may only be carried out with the approval of Hermann Sewerin GmbH.
- Use only Hermann Sewerin GmbH accessories for the product.

Hermann Sewerin GmbH shall not be liable for damages resulting from the non-observance of this information. The warranty conditions of the General Terms and Conditions (AGB) of Hermann Sewerin GmbH are not broadened by this information.

In addition to the warnings and other information in these instructions, always observe the generally applicable safety and accident prevention regulations.

The manufacturer reserves the right to make technical changes.



### 1.2 Purpose

The **LaserGasPatroller** system is used to systematically detect gas leaks. It is permanently installed in a suitable vehicle. The vehicle can then be used as a gas detection vehicle for inspecting aboveground pipes (pipe network inspection).

The **LGP 800** measurement unit is the main component of the system. The system is operated using the **SeCuRi SAT** software.

The **LGP 800** and software communicate by radio (Bluetooth).

The composition of the gas is analysed by laser spectroscopy. The data from the gas analysis is linked to the data from the movement of the vehicle (GPS) and documented in the **SeCuRi SAT** software. Map material from GIS systems can be used for the software.

---

#### Note:

These instructions explain how to assemble, install and start up the **LaserGasPatroller** system.

- The **SeCuRi SAT** software is explained in the corresponding help. You have to open the software to access the help.

These instructions are intended for those who will assemble, install and start up the **LaserGasPatroller** system.

---

### 1.3 Intended use

The product is intended for professional industrial and commercial use. The appropriate specialist knowledge is required to operate the device.

The **LaserGasPatroller** system must only be used for the applications specified in section 1.2.

## 1.4 General safety information

This product was manufactured in keeping with all binding legal and safety regulations. It corresponds to the state-of-the-art and conforms to EC requirements. The product is safe to operate when used in accordance with the instructions provided.

However, if you handle the product improperly, do not assemble, install or start it up properly or do not use it as intended, the product may present a risk to persons and property. For this reason, always observe the following safety information.

- The product must be assembled, installed and started up before it can be used for the first time.
- Before assembling and installing the product, make sure you are aware of the legal regulations governing the use of moving gas detection equipment in the country of operation.
- Conversions and installations to vehicles may be subject to country-specific regulations. Before commencing assembly work, make sure you are aware of the applicable legal regulations in the country of operation.
- The assembled and installed product must never compromise the safety of the vehicle or its passengers. If necessary, adapt the assembly and installation process to the particular features of the vehicle.

## 2 Product description

### 2.1 LaserGasPatroller system

The **LaserGasPatroller** system includes:

- **LGP 800** measurement unit (**LGP 800** for short)
- **SeCuRi SAT** software
- GPS aerial
- **SPE LGP** test set (**SPE LGP** for short)
- Suction tree
- Table housing
- CAN bus adapter

Other mounting options can be used for the **LGP 800** instead of the table housing.

The product also comes with hoses, cables and fixings.

Also required:

- Computer
  - Windows 7 or Windows 8
  - At least 8 GB of RAM
  - Bluetooth interface, alternatively: Bluetooth stick

The **SeCuRi SAT** software is installed on the computer.

SEWERIN recommends: The type of computer used should be a notebook.

### Communication

The **LGP 800** and computer communicate by radio (Bluetooth).

### SPE LGP test set

The **SPE LGP** test set is used as a pressure regulator for the test gas. The **SPE LGP** does not have any controls.

It can be connected to either a test gas can or a test gas bottle.

The **SPE LGP** and **LGP 800** are connected by the test gas hose.

## 2.2 LGP 800

The **LGP 800** GPS-assisted measurement unit is the main component of the **LaserGasPatroller** system. All the analysis and control technology is housed in the **LGP 800**.

Overviews with the names of all the parts of the **LGP 800** can be found inside the front cover (fig. 1 to fig. 3).

### USB port

The USB port on the front is exclusively intended for maintenance work performed by qualified service technicians.

### Switch

The **LGP 800** is switched on and off at the switch. On the top of the switch there are two transparent surfaces which indicate different operating statuses.

	Colour	Operating status
Bar (narrow)	---	There is no voltage at the <b>LGP 800</b> . Explanation: The power supply is automatically switched off if the voltage falls below 10.7 V.
	Orange	There is voltage at the <b>LGP 800</b> .
Square	---	The <b>LGP 800</b> is not switched on.
	Green	The <b>LGP 800</b> is switched on and ready to measure. Exception: Before the system has been set up for the first time, the measurement unit is switched on but is not yet ready to measure.

### Installation options

The **LGP 800** must be securely fixed in the vehicle. It can either be fitted in table housing or in a rack with 19 inch slot (6 rack units).

The table housing is available to buy as an accessory.

---



#### **WARNING!**

#### **Risk of injury to passengers**

If the **LGP 800** is not properly secured, it can slip when the vehicle is in motion. This could cause serious injury to passengers. It could also damage the system or the vehicle.

- Always ensure that the **LGP 800** is securely fixed in the vehicle.
-

### 2.3 Optional system upgrade

The data recorded and evaluated by the **LGP 800** can be used to emit an audible or visual warning of certain events. One such example is a warning if an alarm threshold is exceeded.

The vehicle can be fitted with up to three visual or audible alarms. A visual alarm is a warning light, for example. An audible alarm is a horn, for example.

---

**Note:**

Country-specific regulations will determine whether or not additional visual or audible alarms can - or even must - be fitted to vehicles. There are often certain conditions governing this.

- Before assembling and installing the **LaserGasPatroller**, make sure you are aware of the applicable legal regulations for altering vehicles in the country of operation.

---

The electrical connections of the additional alarms must be fused. The size of the fuse (current in A) must be tailored to the output of the additional alarm.

Information about fuses can be found in section 5.2 on page 36.

### 3 Assembly, installation and starting up

#### 3.1 Overview

##### 3.1.1 General information

The actual extent of assembly work required depends in particular on the configuration of the system and the technical conditions in the vehicle. The nature of the assembly work is always specific to the vehicle.

- Study the vehicle before commencing assembly and installation work.
  - Consider where the individual components can be securely fixed.
  - Check the extent to which hoses and cables can be concealed (e.g. behind the interior trim of the vehicle).
- If necessary, adapt the described assembly work to the specifics of your vehicle and assembly situation.

The product comes with all the main assembly components and some assembly aids (e.g. cable ties).

Assembly aids can be used for assembly, but are not essential. You may have to use other assembly aids that are not provided.



#### **CAUTION!**

The system must be assembled and installed professionally to prevent damage to the vehicle and the **LaserGas-Patroller**. There is also a risk of personal injury if the electrical installations are not technically correct.

- Only trained professionals may assemble, install and start up the system.
-

### 3.1.2 Components

The following overview shows which components need to be assembled.

Component	Recommendations at the installation location
LGP 800	<ul style="list-style-type: none"> <li>● inside the vehicle, e.g. in the boot</li> <li>● install either:               <ul style="list-style-type: none"> <li>– in table housing</li> <li>– in a rack (19 inch slot)</li> </ul> </li> </ul>
GPS aerial	<ul style="list-style-type: none"> <li>● on the roof of the vehicle</li> <li>● on the centre of the vehicle's longitudinal axis</li> <li>● on the back of the roof</li> </ul>
SPE LGP	<ul style="list-style-type: none"> <li>● inside the vehicle, e.g. on the side of the table housing or in the boot on a base plate</li> <li>● close to the <b>LGP 800</b></li> <li>● allow free access to the test gas connection for screwing on the test gas can or the test gas bottle</li> <li>● can be installed anywhere</li> </ul>
Suction tree	<ul style="list-style-type: none"> <li>● to the outside of the vehicle</li> <li>● front centre, e.g. to the metal crossbeam behind the bumper</li> </ul>

All components must be securely fitted so that they do not slip when the vehicle is in motion.

SEWERIN recommends: Equip the boot of the vehicle with a custom-fit wooden floor panel (height  $\geq 13$  mm) if the **LGP 800** is being installed in table housing. The table housing and **SPE LGP** can be securely screwed down to this floor panel. Floor panels are available to purchase as accessories, for example, in the vehicle industry.



#### 3.1.3 Hoses

The following overview shows which hoses need to be laid.

Hose	for connecting	
	from	to
Measuring gas hose	Measuring gas hose inlet (e.g. on radiator grill)	<b>LGP 800</b> (back)
Exhaust gas hose	<b>LGP 800</b> (back)	exhaust gas hose outlet (e.g. side of vehicle body)
Test gas hose	SPE LGP	<b>LGP 800</b> (back)

Measuring gas hose and exhaust gas hose made of transparent PVC. The test gas hose is made of black polyurethane. It has a much smaller diameter than the other two hoses.

#### Information about the exhaust gas hose

After a gas sample has been analysed in the **LGP 800**, this gas has to be expelled from the vehicle as exhaust gas. There are various ways of doing this.

SEWERIN recommends: Fit an outlet for the exhaust gas hose to the side of the vehicle body and connect the hose to it. You will need to drill a hole in the bodywork for the outlet.

#### 3.1.4 Cables

The following overview shows which cables need to be laid.

Cable	for connecting	
	from	to
Power supply	<b>LGP 800</b> (back)	vehicle battery
Aerial	<b>LGP 800</b> (back)	GPS aerial
Reversing and speed signal	<b>LGP 800</b> (back)	vehicle electrics (via CAN bus adapter)

#### **Information about the reversing and speed signal**

The **LGP 800** needs to use the reversing and speed signal to be able to determine the geographical position of the vehicle, even in shadows. Shadows can occur, for example, from large buildings or in tunnels.

SEWERIN recommends: Read both signals out using a CAN bus adapter.

---

#### **Note:**

SEWERIN will be happy to advise you if a CAN bus adapter cannot be fitted to your vehicle.

---

### 3.2 Procedure in detail

---

#### **Note:**

The following sections explain how to assemble and install the system in the order recommended by SEWERIN. You can carry out the steps in a different order if it is more convenient or necessary to do so.

---

#### 3.2.1 Assembly work to the vehicle body

##### 3.2.1.1 Important information

You will need to drill holes in the vehicle body to fit the following components:

- Suction tree (hanging holder)
- GPS aerial
- Exhaust gas hose

Depending on the vehicle, you may also need to drill a hole for the measuring gas hose inlet.

#### **Advice on drilling**

- Always carefully check before commencing that the area you plan to drill is suitable for a borehole.
- If necessary, remove the interior trim before drilling.
- Ensure that you do not drill through any cables or wires.
- Treat all boreholes in metal with antirust agent.

#### **Advice on assembly**

- Secure all threaded connections with special adhesive to ensure that they do not come loose. The adhesive also serves as a seal. This stops moisture from getting into the components fitted to the vehicle body for example.

The adhesive is provided.

#### 3.2.1.2 Fitting the suction tree

General information about fitting the suction tree can be found in section 3.1.2 on page 9.

The suction tree is mounted on a hanging holder. The hanging holder is usually fitted to the metal crossbeam behind the bumper. You will need to drill two holes at a suitable place.

Follow the advice regarding drilling in section 3.2.1.1 on page 12.

The following parts are required for assembly:

- 2 spacer bolts
  - 2 × nuts, washers, spring rings each
- 1 hanging holder
  - 2 × M10 Allen screws

1. Use the hanging holder to mark the distance between the two holes.
2. Drill the holes as follows:
  - a) Pre-drill the holes
  - b) Drill out the holes (diameter 11 mm)
  - c) Only continue drilling out the holes in the plastic skirting (diameter 30 mm)
3. Insert the spacer bolts into the holes from the outside (fig. 4).
4. Tighten the spacer bolts inside.
5. Screw on the hanging holder. Align the hanging holder horizontally with the help of the slotted holes.
6. Mount the suction tree in the hanging holder.

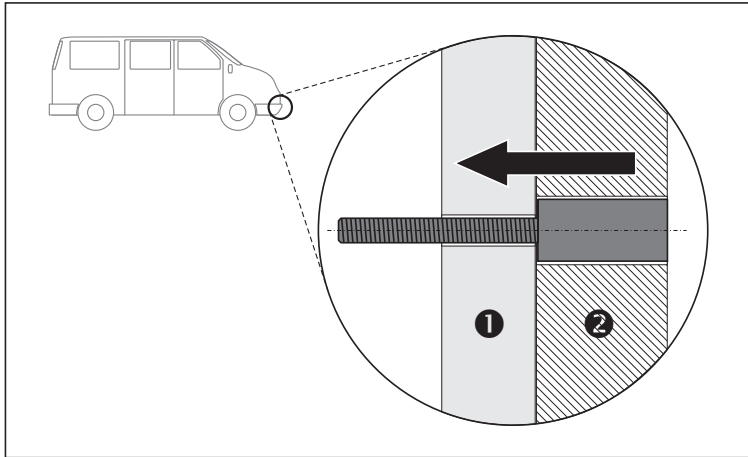

Fig. 4: Fitting direction of spacer bolts 1 metal crossbeam, 2 skirting

#### 3.2.1.3 Fitting the GPS aerial

General information about fitting the GPS aerial can be found in section 3.1.2 on page 9.

The GPS aerial is fitted to the roof of the vehicle. To do this you will need to drill a hole at a suitable spot on the roof.

Follow the advice regarding drilling in section 3.2.1.1 on page 12.

The mounting accessories are supplied with the aerial.

1. Drill a hole (diameter 14 mm).
2. Fit the GPS aerial.
  - a) Align the GPS aerial so that it is centred above the hole.

The GPS aerial has a rubber seal on the base. Check that the outer edge of the seal in particular is neatly seated.
  - b) Push the toothed washer onto the thread to secure the nut.
  - c) Tighten the nut.

### 3.2.1.4 Fitting the outlet for the exhaust gas hose

The outlet for the exhaust gas hose is usually fitted to the side of the vehicle body. To do this, drill a hole at a suitable place.

Follow the advice regarding drilling in section 3.2.1.1 on page 12.

The following parts are required for assembly:

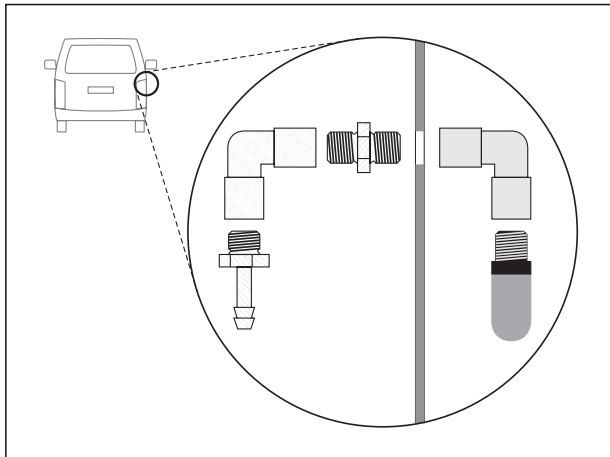
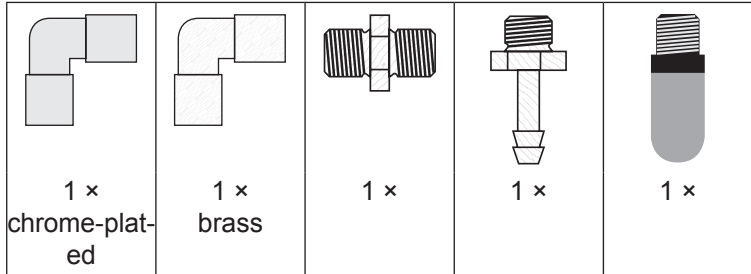

Fig. 5: Fitting the outlet for the exhaust gas hose

1. Drill a hole (diameter 10 mm).
2. Fit the parts as shown in the diagram in fig. 5.
  - Use the chrome-plated bracket on the outside of the vehicle.
  - Make sure the two brackets face downwards.
  - Tighten the connection.

#### 3.2.1.5 Fitting the inlet for the measuring gas hose

The inlet for the measuring gas hose is usually fitted to the radiator grill.

Follow the advice on drilling in section 3.2.1.1 on page 12 if you need to drill a hole at a suitable place.

The following parts are required for assembly:

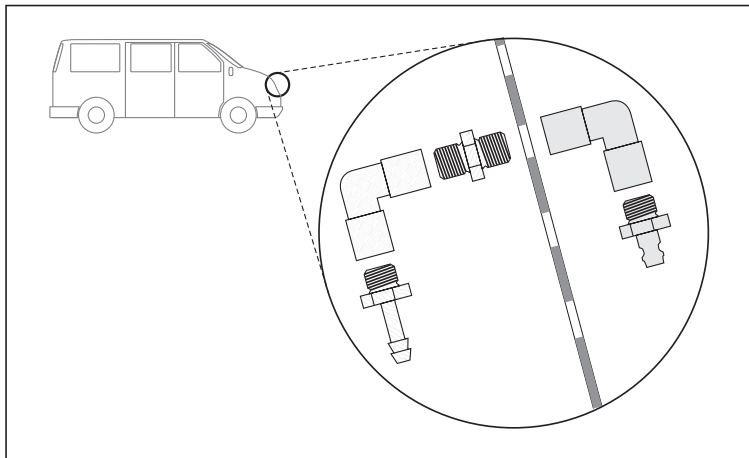
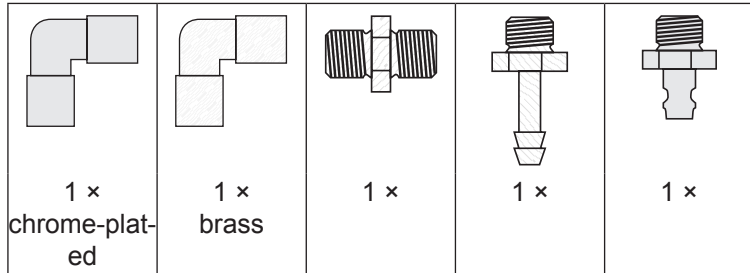

Fig. 6: Fitting the inlet for the measuring gas hose

1. Fit the parts as shown in the diagram in fig. 6.
  - Use the chrome-plated bracket on the outside of the vehicle.
  - Make sure that the bracket on the outside faces downwards. It does not matter which way the bracket inside the vehicle faces.
  - Tighten the connection.

### 3.2.2 Laying the hoses and cables

Information about which hoses need to be laid can be found in section 3.1.3 on page 10.

Information about which cables need to be laid can be found in section 3.1.4 on page 10.

As the options for laying and securing hoses and cables depend on the vehicle, we cannot give any specific instructions in this respect.

#### General information

- Lay the hoses and cables as follows:
  - so that there is no risk of chafing
  - without kinks
  - if possible: behind the vehicle's interior trim
- The hoses and cables provided are longer than required (except the aerial cable). Do not shorten the material before laying. Only shorten it before connecting (see section 3.2.5 and section 3.2.6).

The aerial cable comes ready to fit and does not need to be shortened.

- Lay the hoses the shortest distance possible to avoid the gas having to travel long distances.
- Lay the measuring gas hose and exhaust gas hose so that they are protected against mechanical stress (e.g. from being trodden on).
- Secure all hoses and cables so that they do not slip. To do this, use the assembly aids provided for example (adhesive base, cable ties).



#### 3.2.3 Fitting the LGP 800 – part 1: Preparatory work

##### 3.2.3.1 Fitting the table housing

General information about fitting the **LGP 800** can be found in section 3.1.2 on page 9.

If the **LGP 800** is to be installed in table housing, first fit the table housing inside the vehicle.

The mounting accessories are supplied with the table housing.

1. Position the table housing at the relevant installation location.
2. Mark the four bore holes on the base plate.  
To do this, trace the pre-drilled holes in the table housing.
3. Drill the holes (diameter 8.5 mm).
4. Hammer the drive-in nuts into the holes.
5. Tighten the table housing.
6. Position the **LGP 800** in front of the table housing, but do not slide the **LGP 800** in just yet.

---

##### **Advice on installation in a rack**

If the **LGP 800** is to be installed in a rack, the same applies:

- Position the **LGP 800** in front of the slot, but do not slide the **LGP 800** in just yet.
-

#### 3.2.3.2 Aligning the GPS module in the LGP 800

It is essential that the GPS module faces the direction of travel. The orientation of the **LGP 800** as it is installed in the vehicle, therefore determines the orientation of the GPS module on the support plate.

---

**Note:**

As the system comes customised, the GPS module is usually already facing the right way for the planned installation.

---

A sticker on the housing of the GPS module indicates the correct orientation (fig. 7). The sticker can be seen through the top cover (perforated sheet).

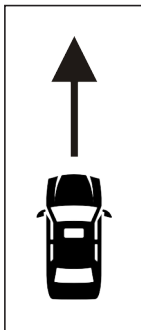

Fig. 7: Aligning the GPS module in the direction of travel (sticker on housing of GPS module)

If the GPS module is not facing the right way, you will need to turn it on the support plate.

There are mounting holes for all four orientation options already on the support plate. The GPS module is secured with four screws.

1. Unscrew the top cover of the **LGP 800**.
2. Undo the screws on the GPS module.
3. Turn the GPS module so that it faces the required direction.
4. Tighten the GPS module again.
5. Screw the cover back on again.

#### 3.2.4 Fitting the SPE LGP

General information about fitting the **SPE LGP** test set can be found in section 3.1.2 on page 9.

SEWERIN recommends: Fit the **SPE LGP** as close to the **LGP 800** as possible to keep the test gas hose short.

---

**Note:**

The test gas can / test gas bottle must be replaced regularly during operation.

- Fit the **SPE LGP** in such a way that the test gas connection is accessible at all times.
- 

1. Position the **SPE LGP** at the desired installation location.
2. Mark the four boreholes.

To do this trace the holes in the mounting straps of the **SPE LGP**.

3. Pre-drill the holes.
4. Secure the **SPE LGP** with suitable screws.

#### 3.2.5 Connecting the hoses

Once you have completed the following steps, you can connect the hoses:

- Assembly work to the vehicle body (section 3.2.1)
- Lay cables (section 3.2.2)
- Position **LGP 800** in front of the table housing or slot

Information on which hose is to be connected where can be found in section 3.1.3 on page 10. Information about connecting the suction tree can be found at the end of this section.

1. Feed the hoses through one of the grommets on the back of the table housing.
2. If necessary, shorten the hoses at each end.

The hoses should be as short as possible,

- but only short enough that the **LGP 800** can be comfortably pushed into and pulled out of the table housing.

3. Connect the hoses to the designated connectors.

fig. 2 in the front cover flap shows the gas connections on the back of the **LGP 800**.

- Measuring gas hose and exhaust gas hose
  - a) Slide the hose ends onto the hose nipples of the connections.
  - b) Secure the hose ends with hose clamps so that they do not slip off.

- Test gas hose

The test gas hose is connected to the test set using a plastic quick-connect.

- a) Slide the hose end onto the hose connector.
- b) Insert the hose connector into the quick-connect.

The test gas hose is connected to the **LGP 800** using a metal quick-release fastener.

- a) Slide the lock nut onto the hose.
- b) Slide the hose end onto the hose nipple.
- c) Secure the connection with the lock nut.

#### **Suction tree**

The suction hose of the suction tree is connected to the inlet of the measuring gas hose.

1. Slide the hose end of the suction hose onto the hose nipple on the exterior of the vehicle.
2. Secure the hose end with a hose clamp so that it does not slip off.

#### 3.2.6 Electrical installation

Once you have completed the following steps, you can connect the cables:

- Fitting the GPS aerial (section 3.2.1.3)
- Lay the cables (section 3.2.2)
- Position **LGP 800** in front of the table housing or slot

---

**Note:**

You will need to remove the right cover plate from the front of the **LGP 800** to connect the following cables.

- Power supply
  - Reversing and speed signal
- 

SEWERIN recommends: Protect any bare wire ends secured in connection terminals with cable end sleeves.

##### 3.2.6.1 Connecting cables for the power supply

The cable for the power supply is connected to the vehicle battery and the **LGP 800**.

##### Connection to the battery

The electrical connection to the battery must be fused. Place the appropriate fuse in a splash-proof fuse holder. The fuse and fuse holder are provided.

SEWERIN recommends: Fit the fuse holder approx. 20 cm from the end of the cable. The fuse holder must be securely fixed close to the battery.

- Think about where in the engine compartment the fuse holder can be secured.



#### **CAUTION! Danger of short-circuit**

The vehicle battery must be switched off and voltage-free before commencing installation work.

- Before commencing installation, undo the earth cable from the battery's negative terminal.
  - Only connect the earth cable to the battery's negative terminal again immediately before starting up.
- 

1. Shorten the cable as far as the battery.
    - Just shorten it enough that the fuse holder can be fitted in between.
  2. Undo the two wires in the cable as far as the planned fuse.
  3. Cut the red wire where the fuse holder is to be fitted.
- 

#### **Note:**

Do not cut the brown wire.

---

4. Fit the fuse holder. Connect the red wire to each side of the fuse holder.
  5. Firmly secure the fuse holder in the engine compartment.
  6. Place eye rings on both wires at the end of the cable.
  7. Place the appropriate fuse in the fuse holder.
  8. Connect the cable to the battery's terminal posts as follows:
    - Current: red wire to positive terminal
    - Earth: brown wire to negative terminal
- 

#### **NOTICE!**

The **LGP 800** reacts sensitively to transfer resistance.

- It is essential that you connect the earth to the battery's negative terminal. Do not connect the earth to the vehicle body, as is possible in other cases.
-

#### Connecting to the LGP 800

1. Feed the cable through one of the grommets on the back of the table housing.
2. Shorten the cable if necessary.
  - Only shorten it enough that the **LGP 800** can be comfortably pushed into and pulled out of the table housing.
3. The cable comes with a connection terminal at one end.
  - Fit the connection terminal back on the cable end if it has been removed for laying or shortening.
4. Insert the connection terminal into the **BAT** port.

You can access the **BAT** port by removing the right cover plate from the front of the **LGP 800**.

The cable must be fed through the **LGP 800** from the inside to the front to connect it.

#### 3.2.6.2 Connecting the cable for the reversing and speed signal

The cable for the reversing and speed signal is connected to the CAN bus adapter and the **LGP 800**.

Information about the reversing and speed signal can be found on page 11.

1. Connect the cable to the CAN bus adapter.
  - Reversing signal: brown wire
  - Speed signal: grey-blue wire
2. Shorten the cable if necessary.
  - Only shorten it enough that the **LGP 800** can be comfortably pushed into and pulled out of the table housing.
3. Fit the connection terminal to the other end of the cable.

The connection terminal is provided.

Ensure the correct allocation.

  - Reversing signal: brown wire > **BWD**
  - Speed signal: grey-blue wire > **ODM**
4. Insert the connection terminal into the appropriate ports:

You can access the **ODM/BWD** port by removing the right cover plate from the front of the **LGP 800**.

The cable must be fed through the **LGP 800** from the inside to the front to connect it.

#### 3.2.6.3 Connecting the aerial cable

The aerial cable is connected to the GPS aerial and the **LGP 800**. It is connected to the **LGP 800** by way of a short pre-fitted aerial cable with FME plug.

The aerial cable comes ready to fit.

1. Connect the FME angled socket to the GPS aerial.
2. Feed the short aerial cable pre-fitted to the **LGP 800** out through one of the grommets on the back of the table housing.
3. Connect the straight FME socket on the FME plug of the short aerial cable.

#### 3.2.7 Setting up the system

Setting up the system also allows you to check that it is working properly.

SEWERIN recommends: Only finish installing the **LGP 800** when all the steps in this section have been successfully completed.

Once you have completed the following steps, you can set up the system:

- Assembly work to the vehicle body (section 3.2.1)
- Laying the hoses and cables (section 3.2.2)
- Fitting the **LGP 800** – part 1: Preparatory work (section 3.2.3)
- Fitting the SPE LGP (section 3.2.4)
- Connecting the hoses (section 3.2.5)
- Electrical installation (section 3.2.6)

The **SeCuRi SAT software** must be installed on the computer used in the vehicle.

---

#### Note:

SEWERIN will be happy to help if you have any questions about installing the **SeCuRi SAT** software.

---



The following steps are involved in setting up the system:

1. Connect the earth cable to the battery's negative terminal.
2. Switch on the **LGP 800**.
3. Check the operating status of the **LGP 800**.

The **LGP 800** is ready to measure when the square on the switch is green.

4. Pair the **LGP 800** and the computer.

For information on this please see section 3.2.7.1.

5. Configure the **SeCuRi SAT** software.

For information on this please see section 3.2.7.2.

6. Start up the system for the first time.

For information on this please see section 3.2.7.3.

### 3.2.7.1 Pairing the LGP 800 and computer by Bluetooth

In order to communicate by Bluetooth, the **LGP 800** and the computer need to be assigned to each other once. This process is known as "pairing". Devices that have been assigned to each other can connect to each other at any time.

The steps explained below refer to Windows 7. The procedure might differ slightly with other operating systems.

Further information about setting up Bluetooth connections can also be found at Microsoft ([windows.microsoft.com](http://windows.microsoft.com)) using the keyword "Bluetooth".

Computer and **LGP 800** are switched on.

1. Click on the **Bluetooth devices** icon in the info pane of the Windows status bar on the computer. A shortcut menu opens.

The icon is often hidden. If it is hidden, click on the up arrow Show hidden icons to display it.

2. Select **Add device**. Windows will search the surrounding area for available devices.

A list of the available devices will appear. The **LGP 800** will appear in the list as **FirePlug-xxxx**. **xxxx** is a specified combination of numbers and letters.

3. Select **FirePlug-xxxx**.
4. Click **Next**.
5. Select **Enter pairing code for device**.
6. Enter the pairing code **1234**.
7. Click **Next**. The device driver is installed. The **Add device** window closes.

**The LGP 800** and computer have been paired.

#### 3.2.7.2 Configuring the SeCuRi SAT software

1. Open the **SeCuRi SAT** software. The workpane will appear.
2. Click on the SEWERIN icon in the top left corner. A menu will appear.
3. Select **Settings > User settings**. The **User settings** tab will appear.
4. Select **GPS** in the navigation bar on the left. The **Configuration** tab will appear alongside on the right.
5. Adjust the necessary settings.

Use the values and entries contained in the software help. You can find information under **SeCuRi SAT Complete Manual > LGP 800 user settings > GPS user settings**.

6. Select **SeCuRi SAT device control** in the navigation bar on the left. The **Configuration** tab will appear alongside on the right.
7. Adjust the necessary settings.

Use the values and entries contained in the software help. You can find information under **SeCuRi SAT Complete Manual > LGP 800 user settings > LGP 800 user settings**.

#### COM port values

If you do not know the assigned COM port, you can obtain information about existing Bluetooth connections from the info pane of the Windows status bar via the **Bluetooth devices** icon.

- The icon is often hidden. If it is hidden, click on the up arrow **Show hidden icons** to display it.
  - Click on the **Bluetooth devices** icon. The **Display Bluetooth network devices** window will appear.
  - Right click on the relevant device. A shortcut menu opens.
  - Select **Properties > Hardware**. A list of connected devices will appear.
  - Move the mouse over the relevant device. A Tooltip will appear showing the assigned COM port.
8. Click on the close button (x) of the **User settings** tab. Configuration of the software is complete. The workpane will appear again.
  9. Click on **Complete**. The system is ready to measure.

### 3.2.7.3 Starting up the system for the first time

The system is piloted to complete the setting up process. Starting up the system for the first time also serves to ensure that it is working properly.

The **LGP 800** is switched off. The **SeCuRi SAT** software is not open. A suitable test gas is connected to the **SPE LGP** test set (test gas can or test gas bottle).

The measuring process is simulated. SEWERIN recommends: Use a test gas with at least 100 ppm CH<sub>4</sub> for the simulation.

1. Switch on the **LGP 800**.
2. Launch the software.
3. Select **Complete** in the software.
4. Click on **Connection** in the toolbar. The computer connects to the **LGP 800**.

Once the connection has been established, the **Device inspection** icon becomes active in the toolbar.

5. Click on **Device inspection** in the toolbar. Test gas is automatically fed to the **LGP 800** via the test set.

Once the device inspection has been successfully completed, the **Start** icon becomes active in the toolbar.

6. Click on **Start** in the toolbar. A window displaying the measurement values appears.
7. Feed gas into one of the bells of the suction tree. Use the recommended test gas.
8. Check the display under **Current measurement value**. The measurement value displayed must be at least 3 ppm.

When all the steps have been completed without any problems, the starting up process is complete.

#### 3.2.8 Fitting the LGP 800 – part 2: Installation

Once the system has been set up and is working (section 3.2.7), you can finish fitting the **LGP 800**.

The mounting accessories are supplied with the table housing.

1. Slide the **LGP 800** into the table housing or the slot in the rack.
  - Take care when pulling any cables and hoses.
  - Ensure that cables and hoses do not kink.
2. Screw the **LGP 800** to the cage nuts on the front.

## 4 Information on operation and servicing

### 4.1 Operation

#### 4.1.1 Device inspection when starting the system

Test gas is fed to the **LGP 800** every time the system is started to ensure that the sensor is working correctly and to set the zero point.

This process is started in the software via **Device inspection** in the menu.

---

**Note:**

The system is only ready to measure when the device inspection is complete.

---

#### 4.1.2 Determining the geographical position

The geographical position is determined regularly and automatically when the vehicle is moving. The system also calibrates the GPS speed with the vehicle's speed signal.

##### **Starting up**

When starting up for the first time, the calibration takes approx. 10 minutes from the beginning of the journey. During this time the system is not yet ready to measure.

SEWERIN recommends: Switch the system on before you drive off so that you can use the journey to the site for the calibration.

##### **Starting up again**

If the system has been out of use for a long time (3 months or more), the first calibration also takes approx. 10 minutes.

### 4.1.3 Switching off the system

At the end of the shift, the system must be switched off in the following order:

1. Close the software.
2. Shut down the computer.
3. Switch off the **LGP 800**. The green light on the switch will go out.

## 4.2 Maintenance

The filters in the system need to be checked regularly and replaced if dirty.

Component	Type of filter	Number of filters
LGP 800	hydrophobic filter	1
Suction tree	hydrophobic filter	1
	hose filter	2
Bells	probe filter inset	1 for each bell

SEWERIN recommends: Perform a visual inspection of the filters every week. The filter in the **LGP 800** should be checked every 3 months.

### Visual inspection and changing the filters on the LGP 800

1. Remove the bottom cover plate from the front of the **LGP 800**.
2. Check the hydrophobic filter for dirt.
3. Replace the filter if it is dirty.
  - a) Pull the hoses off each side of the filter.
  - b) Replace the filter.
  - c) Slide the hose ends back onto the filter.
4. Fit the bottom cover plate back onto the front of the **LGP 800**.

### **Changing the filters on the suction tree**

The hydrophobic filter and hose filter are replaced in the same way.

1. Pull the hoses off each side of the filter.
2. Replace the filter.
3. Slide the hose ends back onto the filter.

### **Changing the filter on a bell**

1. Unscrew the bell.
2. Replace the probe filter inset.
3. Screw the bell back on.



## 5 Appendix

### 5.1 Technical information: LGP 800

#### Device data

Dimensions (W × D × H):	48.3 × 35, 6 × 26.7 cm (19" × 8 HP × 6 U)
Weight	approx. 10 kg approx. 15 kg with table housing

#### Certificates

Certificate	E13*10R00*10R04*13309*00
Marking	CE  10R-0413309

#### Features

Interface	Bluetooth, USB
Processor	Microcontroller 8 bit Dual USB Host Controller
GPS	with dead reckoning
Sensor	laser
Pump	suction pump, 14 l/min

#### Operating conditions

Operating temperature	-10 °C – +50 °C
Storage temperature	-40 °C – +80 °C
Humidity	0 – 99 % r.h., non-condensing
Atmospheric pressure	800 – 1100 hPa
Protection rating	IP20
Non-permitted operating environments	in explosion-protected areas off-road
Normal position of use	installed horizontally in the vehicle

#### Power supply

Power supply	12 V
	without external alarms: max. 2 A
	without external alarms: max. 20 A

**GPS**

Accuracy	approx. 2.5 m
Measuring technique, additional	dead reckoning
Aerial	external

**Laser sensor**

Gas type	CH <sub>4</sub>
Measuring range	0 – 40,000 ppm in synthetic air
Resolution	0.1 ppm at 1 s integration time
Response times	2 s
Warm-up time	0.5 min
Flow rate	maximum 5 l/min
Measuring error	±2 % of measurement value or ±2 ppm (the higher value applies)
Interference	none known
Lifetime, expected	5 years

**Additional data**

Type of cable	power supply: 2 × 6 mm <sup>2</sup> aerial: RG58 FME, ready to fit reversing/speed signal: FLY 1 × 0.75 mm <sup>2</sup> (2x)
Cable length	power supply: 5 m aerial: 4 m or 6 m reversing/speed signal: 5 m
Attachment option	installation in table housing or rack (19")

**Computer system requirements**

Operating system	Windows 7, Windows 8 (32/64 bit)
RAM	minimum 8 GB
Interface	USB, Bluetooth (or Bluetooth stick)
Screen resolution	1024 × 768

5.2 Fuses

Fuse	Type	Current [A]	Use	Remark
F1	ATOF yellow	20	battery (main fuse)	
F2	ATOF grey	2	battery sensor	only when using an external battery sensor (F12 free in this case)
F3	Microfuse M 250 mA	0.25	sensor module	
F4	Microfuse M 250 mA	0.25	GPS module	
F5	ATOF grey	2	pump	
F8	ATOF grey	2	interface module	
F9	ATOF	depends on load	OUT1	only if external alarm is connected
F10			OUT2	
F11			OUT3	
F12	ATOF grey	2	battery sensor	only if using internal battery sensor (factory setting) or external battery sensor at F2

### 5.3 Accessories and consumables

#### Accessories

Part	Order number
SPE LGP test set	PP01-10401
LGP 800 table housing	FP03-Z0100
"Medi" Notebook holder	9090-0009
"Medi-Plus" Notebook holder	9090-0010
"Maxi" Notebook holder	9090-0011
Display support	9090-0012
CAN bus adapter	FP02-Z5000
Suction tree universally split	ZS35-10000

#### Consumables

Part	Order number
Test gas can 10 ppm CH <sub>4</sub>	ZT24-10000
Test gas can 100 ppm CH <sub>4</sub>	ZT24-10100
Test gas can 1000 ppm CH <sub>4</sub>	ZT29-10001
Hydrophobic filter	2491-0050
Hose filter	2499-0010
Probe filter element	2499-0005
Automotive fuse ATOF 32 V 2 A grey	1361-0001
Automotive fuse ATOF 32 V 3 A violet	1361-0002
Automotive fuse ATOF 32 V 5 A beige	1361-0003
Automotive fuse ATOF 32 V 20 A yellow	1361-0004
Automotive fuse MAXI 32 V 20 A yellow	1361-0005
Microfuse DIN 41571 M 250 mA	1362-0250

Other accessories and consumables are available for the product. Please contact our SEWERIN sales department for further information.

#### 5.4 Declaration of conformity

Hermann Sewerin GmbH hereby declares that the **LGP 800** measurement unit fulfils the requirements of the following directives:

- 1999/5/EC
- 2009/19/EC

The complete declaration of conformity can be found online.

#### 5.5 Advice on disposal

The European Waste Catalogue (EWC) governs the disposal of appliances and accessories.

Description of waste	Allocated EWC waste code
Device	16 02 13
Test gas can	16 05 05

#### End-of-life equipment

Used equipment can be returned to Hermann Sewerin GmbH. We will arrange for the equipment to be disposed of appropriately by certified specialist contractors free of charge.

---

## 6 Index

### A

- alarms, external 7
- aligning the GPS module 19
- assembly
  - general information 8
  - overview 9
  - to vehicle body 12

### B

- backups 36
- bell, replacing the filters 33

### C

- cable
  - connecting for aerial 25
  - connecting for the power supply 22
  - connecting for the reversing and speed signal 24
  - laying 17
  - overview 10
- communication 4
- configuring the software 28
- connecting the aerial cable 25

### D

- determining the geographical position 31
- device inspection 31

### E

- electrical installation 22
- exhaust gas hose
  - fitting the outlet 15
  - note 10

### F

- fitting the table housing 18

### G

- GPS aerial
  - fitting 14
  - installation location 9

### H

- hoses
  - connecting 20
  - laying 17
  - overview 10

### I

- installation
  - electrical 22
  - general information 8

### L

- LGP 800 5
  - fitting (part 1) 18
  - fitting (part 2) 30
  - installation location 9
  - installation options 6
  - pairing with computer 27
  - replacing the filters 32
  - switch 5
  - USB port 5

### M

- measuring gas hose, fitting the inlet 16

### P

- pairing 27

### R

- replacing the filters 32
- reversing and speed signal 11

### S

- SPE LGP test set 4
  - fitting 20
  - installation location 9
- suction tree
  - connecting the hoses 21
  - fitting 13
  - installation location 9
  - replacing the filters 33
  - switch 5

## 6 Index

---

### system

- device inspection when ~starting up  
31
- ~extension, optional 7
- overview 4
- setting up 25
- starting up 29
- switching off 32

## U

- use, intended 2



**Hermann Sewerin GmbH**

Robert-Bosch-Straße 3  
33334 Gütersloh, Germany  
Tel.: +49 5241 934-0  
Fax: +49 5241 934-444  
[www.sewerin.com](http://www.sewerin.com)  
[info@sewerin.com](mailto:info@sewerin.com)

**SEWERIN SARL**

17, rue Ampère - BP 211  
67727 Hoerdts Cedex, France  
Tél. : +33 3 88 68 15 15  
Fax : +33 3 88 68 11 77  
[www.sewerin.fr](http://www.sewerin.fr)  
[sewerin@sewerin.fr](mailto:sewerin@sewerin.fr)

**SEWERIN IBERIA S.L.**

Centro de Negocios Eisenhower  
Avenida Sur del Aeropuerto de  
Barajas 24, Ed. 5 Of. 2C  
28042 Madrid, España  
Tel.: +34 91 74807-57  
Fax: +34 91 74807-58  
[www.sewerin.es](http://www.sewerin.es)  
[info@sewerin.es](mailto:info@sewerin.es)

**Sewerin Ltd**

Hertfordshire  
UK  
Phone: +44 1462-634363  
[www.sewerin.co.uk](http://www.sewerin.co.uk)  
[info@sewerin.co.uk](mailto:info@sewerin.co.uk)

**Sewerin Sp.z o.o.**

ul. Twórcza 79L/1  
03-289 Warszawa, Polska  
Tel.: +48 22 675 09 69  
Faks: +48 22 486 93 44  
Tel. kom.: +48 501 879 444  
[www.sewerin.pl](http://www.sewerin.pl)  
[info@sewerin.pl](mailto:info@sewerin.pl)